

MODEL  
EHPT180VM

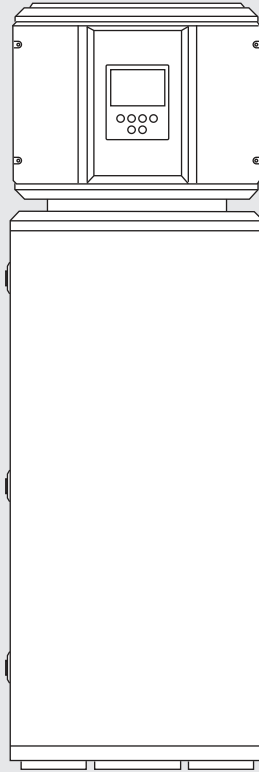

# Heat Pump Hot Water System

## Operation & Installation Manual

**Rinnai**

This appliance must be installed in accordance with:

- Manufacturer's Installation Instructions
- Current AS/NZS 3500
- Plumbing Code of Australia (PCA)
- Local Regulations and Municipal Building Codes including local OH&S requirements

This system must be installed, commissioned, serviced, maintained and removed **ONLY** by an Authorised Person.

**NOT SUITABLE AS A POOL OR SPA HEATER**

For continued safety of this appliance it must be installed and maintained in accordance with the manufacturer's instructions.



Certified  
Product  
  
WaterMark  
AS3498 Lic W00169  
SAI Global



# TABLE OF CONTENTS

<b>Warnings and Important Information</b>	<b>4</b>
Safety and Regulatory Information .....	4
Transport and Storage of Appliance .....	5
Scald Hazards .....	6
Operating Principle .....	7
System Schematic .....	7
Safety Devices .....	7
Excessive Discharge from Safety Devices .....	8
Hydrogen Gas .....	9
Turning On the Water Heating System .....	9
Turning Off the Water Heating System .....	9
Draining and Filling .....	9
Maintenance and Regular Care .....	9
<b>Save a Service Call</b>	<b>10</b>
Fault Codes .....	11
<b>Specifications</b>	<b>12</b>
System Specifications .....	12
Dimensions .....	13
Clearances .....	14
<b>Installation</b>	<b>15</b>
Regulations and Occupation Health and Safety (OH&S) .....	15
Location .....	15
Water Supply .....	16
Storage Temperature .....	16
Hot Water Delivery Temperature .....	16
Valves and Fittings .....	17
Transport and Handling .....	17
Positioning the Heat Pump .....	18
Connect the PTR Valve .....	18
Plumbing Connections .....	18
Connect Cold / Hot Water Supply .....	19
Connect Condensate Drain line .....	19
Typical Plumbing Layout .....	20
Electrical Connections .....	20
Wiring Schematic .....	21
Electrical Tests .....	22
Filling the System .....	22
Commissioning and Finishing the Installation .....	22
Controller Layout .....	23
Operating Functions .....	24
Wi-Fi Connection .....	26
<b>Contacts</b>	<b>28</b>

# WARNINGS AND IMPORTANT INFORMATION

## SAFETY AND REGULATORY INFORMATION



**DO NOT** operate this system before reading the manufacturers instructions.

This appliance must be installed, commissioned and serviced by an authorised person in accordance with all applicable local rules and regulations.

Access covers of water heating system components will expose 240V wiring and **MUST** only be removed by an authorised person.

This appliance is not intended for use by persons (including children) with reduced physical, sensory or mental capabilities, or lack of experience and knowledge, unless they have been given supervision or instruction concerning use of the appliance by a person responsible for their safety.

For continued safety of this appliance it must be installed, operated and maintained in accordance with the manufacturer's instructions.

Children should be supervised to ensure they **DO NOT** play with the appliance.

The Heat Pump is fitted with a power cord & 15 amps plug , It **MUST** connect to an independent, fused, AC 240V 50 Hz power supply with an isolating switch installed at the switch board, which shall effectively isolate all active supply conductors from the circuit and means for disconnection **MUST** be incorporated in the fixed wiring in accordance with the wiring rules. If the power supply cord is damaged, it **MUST** be replaced by an authorised person in order to avoid a hazard. Take care not to touch the power connections or plugs with wet hands.

Care should be taken not to touch the pipe work as it may be HOT!

**DO NOT** place articles on or against this appliance.

**DO NOT** store chemicals or flammable materials near this appliance.

**DO NOT** operate with collectors or covers removed from this appliance.

**DO NOT** activate heat pump unless cylinder is full of water.

**NEVER** use a flammable spray such as hair spray, paint, etc near this unit as this may cause a fire.



### MANDATORY INSPECTION PRIOR TO INSTALLATION

Immediately report any damage or discrepancies to the Supplier of the appliance. This appliance was inspected and tested at the time of manufacture and packaging, and released for transportation without known damage. Upon receipt, inspect the exterior for evidence of rough handling in shipment. Ensure that the appliance is labelled correctly for the gas and electrical supply, and/or other services it is intended to be connected to.

For safety and warranty purposes, appliances that may be damaged or incorrect must not be installed or operated under any circumstances. Installation of damaged or incorrect appliances may contravene local government regulations. Rinnai disclaims any liability or responsibility whatsoever in relation to the installation or operation of damaged or incorrect appliances.

### NOTICE TO VICTORIAN CONSUMERS

This appliance must be installed by a person licensed with the Victorian Building Authority.

Only a licensed person will have insurance protecting their workmanship.

So make sure you use a licensed person to install this appliance and ask for your Compliance Certificate.

For further information contact the Victorian Building Authority on 1300 815 127

**TRANSPORT AND STORAGE OF APPLIANCE**



The appliance(s) shall be stored and transported in an area without ignition sources (for example: open flames, an operating gas appliance or an operating electric heater)

**DO NOT** pierce or burn the appliance.

Be aware that refrigerants may not contain an odour.

Compliance with AS/NZS 5149 **MUST** be observed while storing the appliance.



National and state regulations exist for storage, handling and transport of hazardous goods including flammable gasses. The maximum number of pieces of equipment or the configuration of the equipment, permitted to be transported or stored together will be determined by the applicable regulations.



**IMPORTANT  
DO NOT TILT  
MORE THAN 45°  
FROM VERTICAL**

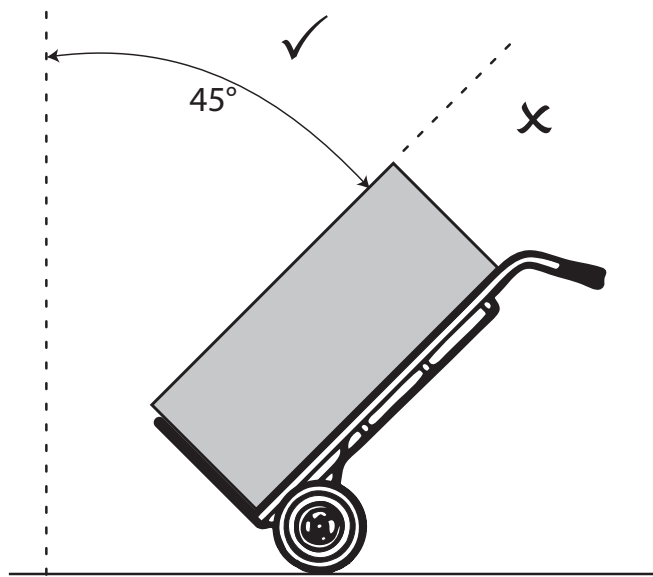

The Rinnai Electric Heat Pump must be transported at an angle no greater than 45° from vertical. As the compressor unit is located at the top of the electric heat pump, should the heat pump be tilted at a greater angle than 45° from vertical, the lubrication oil within the compressor can run down into the mufflers. This will leave the compressor motor without sufficient lubrication and lead to premature failure of the compressor unit.

As a general good practice it is better to keep the compressor upright as much as possible to avoid any risks. Returning the Rinnai Electric Heat Pump to a vertical position will allow the oil to properly flow back into the compressor motor.

Tilting beyond 45° from vertical will also place undue strain on compressor motor mounts and associated piping.



**Do not use means to accelerate the defrosting process or to clean, other than those recommended by the manufacturer.**

The appliance shall be stored in a room without continuously operating ignition sources. For example, open flames, an operating gas appliance or an operating electric heater.

**Do not pierce or burn.**

Be aware that refrigerants may not contain an odour.

**SCALD HAZARDS**

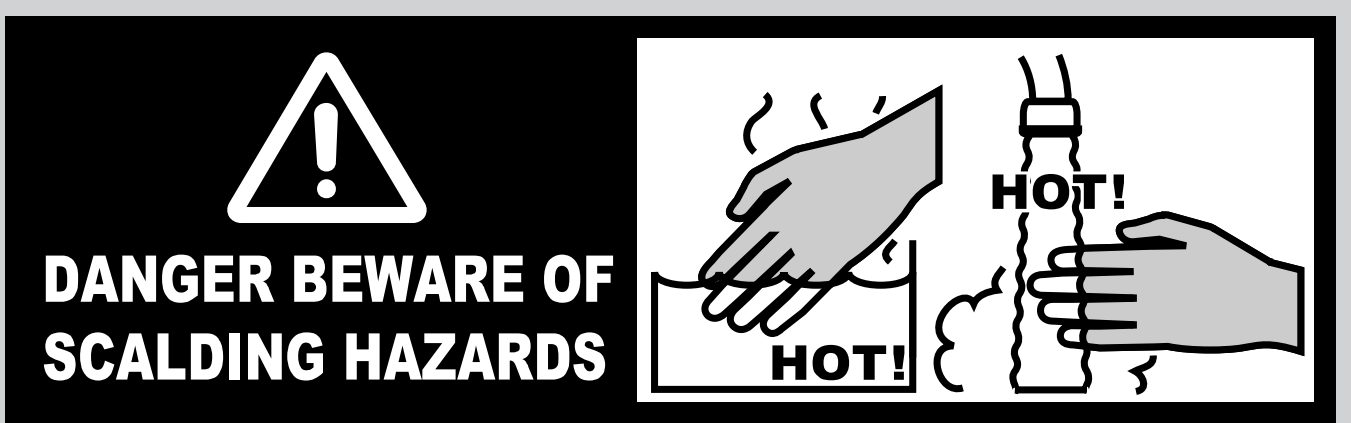

**HOT WATER CAN CAUSE SCALDS.**

**CHILDREN, DISABLED, ELDERLY AND THE INFIRM ARE AT THE HIGHEST RISK OF BEING SCALDED.**

**FEEL WATER TEMPERATURE BEFORE BATHING OR SHOWERING.**

**SCALDS FROM HOT WATER TAPS CAN RESULT IN SEVERE INJURIES TO YOUNG CHILDREN.**

**SCALDS OCCUR WHEN CHILDREN ARE EXPOSED DIRECTLY TO HOT WATER WHEN THEY ARE PLACED INTO A BATH WHICH IS TOO HOT.**

**ALWAYS.....**

Test the temperature of the water with your elbow before placing your child in the bath, also carefully feel water before bathing or showering yourself.

Supervise children whenever they are in the bathroom.

Make sure that the hot water tap is turned off tightly.

**CONSIDER.....**

Installing child proof tap covers or child resistant taps (both approaches will prevent a small hand being able to turn on the tap).

Installing tempering valves or thermostatic mixing valves which reduce the hot water temperature delivered to the taps. Your local plumbing authority may already require that these be fitted. Contact your installer or local plumbing authority if in doubt.

**NEVER....**

Leave a toddler in the care of another child. They may not understand the need to have the water temperature set at a safe level.

**OPERATING PRINCIPLE**

The operation of an electric heat pump is very similar to a refrigerator, but in reverse. A heat pump operates by transferring heat from the ambient outside air into the water. Electricity is just used to operate the system, but not to directly heat the water. Because of this energy consumption is significantly reduced as compared to an electric element hot water system. The warmer the climate in which the heat pump is installed, the more efficient the heat pump system will be at heating water.

The heat pump unit includes highly efficient copper tube heat exchanger wrapped around the inner cylinder for thermal conductivity. A temperature sensor in the tank is used to control the heat pump operation to achieve suitable tank temperature.

During the occasional times when the ambient weather conditions aren't suitable for the heat pump to operate, the electric element will provide heating to ensure a supply of hot water.

**SYSTEM SCHEMATIC**

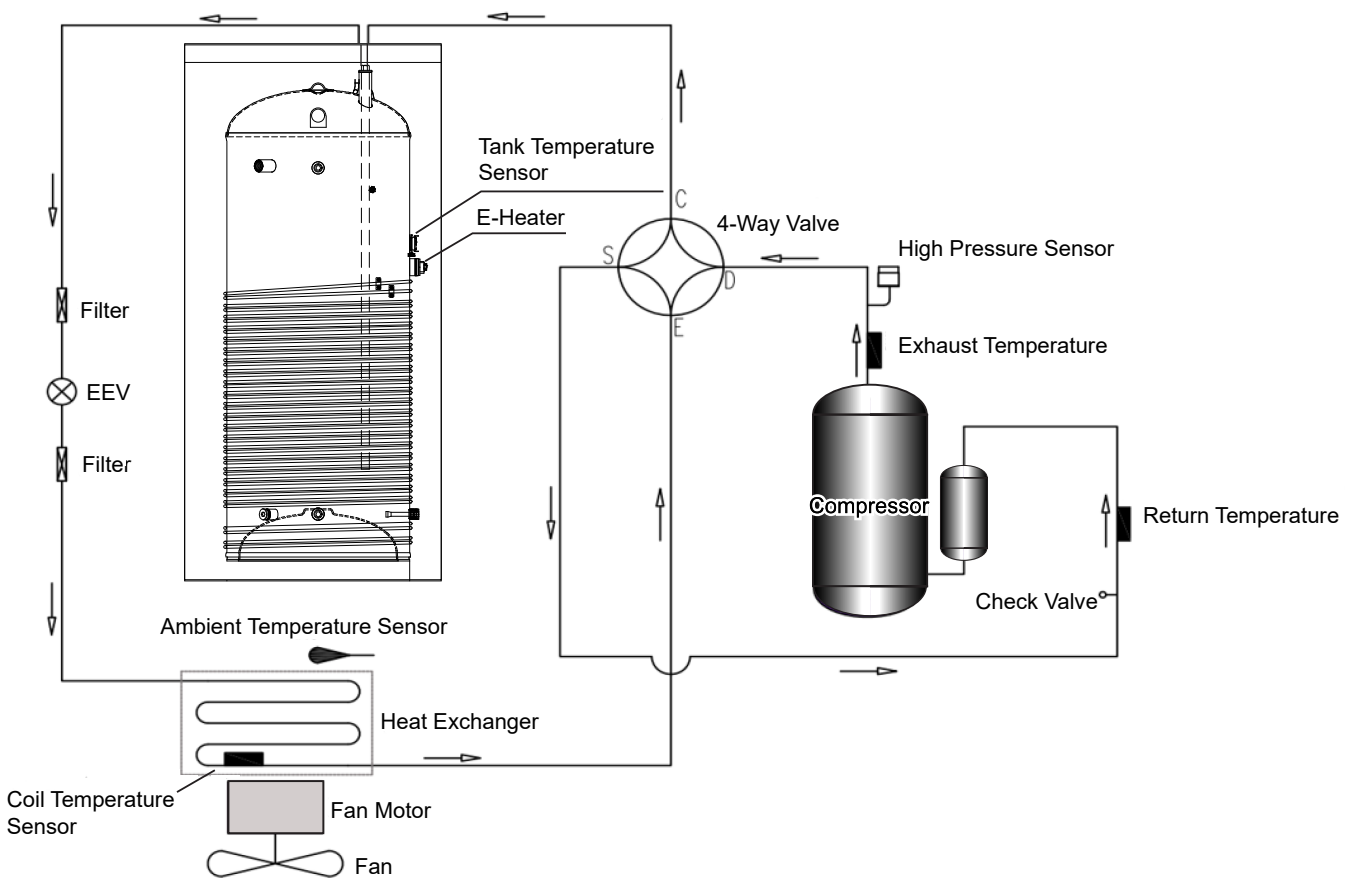

**SAFETY DEVICES**

The water heating system is supplied with various safety devices including temperature sensors, overheat sensors and switches and a Pressure & Temperature Relief (PTR) valve. These devices must not be tampered with or removed. The water heating system must not be operated unless each of these devices is fitted and is in working order.

 **DO NOT tamper with or remove safety devices.**  
**DO NOT operate the water heater unless all safety devices are fitted and in working order.**  
**DO NOT block or seal the PTR Valve and drain pipe.**

## WARNINGS AND IMPORTANT INFORMATION

### Pressure & Temperature Relief (PTR) Valve

This valve is located near the top of the water heater and is essential for safe operation. It is normal for the valve to release a small quantity of water through the drain line during heating.

However, continuous leakage of water from the valve and its drain line may indicate a problem with the water heater.

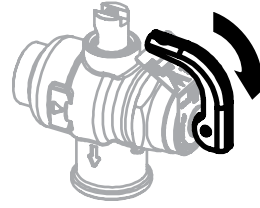

Lift lever until water flows from drain line (Lower lever gently!)



**NEVER** block the outlet of the PTR valve or its drain line for any reason. The easing gear **MUST** be operated at least every 6 months to remove lime deposits and verify that it is not blocked. Failure to do this may result in the water heater failing.

If the valve does not discharge water when the easing gear lever is opened, or does not seal again when the easing gear is closed, attendance by an authorised person **MUST** be arranged without delay. The PTR valve is not serviceable.

## EXCESSIVE DISCHARGE FROM SAFETY DEVICES

### Pressure & Temperature Relief (PTR) Valve

It is normal and desirable that this valve allows a small quantity of water to be discharged during the heating cycle. If it discharges more than a bucket of water during a 24 hour period or discharges continuously there may be another problem.

If the valve dribbles continuously, try easing the valve gear for a few seconds as described above. This may dislodge any foreign matter and alleviate the problem.

If the valve discharges at high flows, especially at night, it may be as a result of the water pressure exceeding the design pressure of the water heater. Ask your installer to fit a Pressure Limiting Valve (PLV).



**NEVER** replace the PTR valve with one which has a higher pressure rating than is specified for your water heater.

### Expansion Control Valve (ECV) - if required

It is normal that this valve allows a small quantity of water to be discharged during the heating cycle. If it discharges more than a bucket of water during a 24 hour period or discharges continuously there may be another problem.

If the valve leaks continuously, try easing the valve gear for a few seconds. This may dislodge any foreign matter and alleviate the problem. If it does not, please contact Rinnai.

Operate the easing gear regularly to remove any lime deposits and to verify that it is not blocked.



**HYDROGEN GAS**

If the hot water unit is not used for two weeks or more, a quantity of hydrogen gas, which is highly flammable, may accumulate in the water heater. To dissipate this safely, it is recommended that a non-electrically operated hot tap be turned on for two minutes at a sink, basin, or bath, but not a dishwasher or other appliance. During this procedure there **MUST** be no smoking, open flame or any electrical appliance operating nearby. If hydrogen is discharged through the tap, it will probably make a sound like air escaping.

**TURNING ON THE WATER HEATING SYSTEM**

Switch on the electric supply to the heat pump unit. Water heating will now occur as required. It may take a number of hours before hot water is available.

**TURNING OFF THE WATER HEATING SYSTEM**

If you plan to be away for only a few nights, we suggest you leave the water heating system switched on. If it is necessary to switch off the water heater, do so as outlined below:



**DO NOT** turn power off to the heat pump unit if snow or frost conditions are expected as components in the system may be damaged by freezing. If power needs to be turned off or power failure occurs and freezing conditions are expected, the water needs to be drained from the heat pump unit. Follow the procedure described below in the section 'Draining and Filling'.

**DRAINING AND FILLING**

Draining or filling of the complete system normally only occurs during installation or servicing and must be carried out by an authorised person.

Draining water from the heat pump unit is necessary if the power will be shut off to the unit and snow or frost conditions are expected. **Arrange for an authorised person to carry out this task.**

To drain the heat pump:

1. Turn off power to the heat pump
2. Close the cold water mains supply stop cock
3. Open a hot tap to relieve pressure
4. Disconnect the hot outlet near the top of the storage cylinder
5. Disconnect the cold inlet near the bottom of the storage cylinder.
6. The system will now drain completely.

**MAINTENANCE AND REGULAR CARE**

Operate the easing gear of the PTR and the ECV if fitted as described in the section 'Safety Devices' on page 7.

The overflow tray (supplied by installer) and drain underneath the storage cylinder (if fitted) should be periodically checked to ensure there are no blockages.



**DO NOT** drill, screw or fix any ancillary items to the of the tank. This product is fitted with a high efficiency heat exchanger attached to the inner cylinder, anything penetrating the outer skin of the tank may damage the heat exchanger.

# SAVE A SERVICE CALL

Rinnai's servicing network personnel are fully trained and equipped to give the best service on your Rinnai appliance. If your appliance needs service, ring one of the service contact numbers on the back of this booklet.

The pressure and temperature relief valve and expansion control valve (if fitted) must be replaced by an authorised person at intervals not exceeding 5 years or more frequently in areas where the water is classified as scaling water.

If the power supply cord to the heat pump unit is damaged, they must be replaced by an authorised person in order to avoid a hazard.

Use the following guide to avoid the need for an unnecessary service call.

<b>INSUFFICIENT OR NO HOT WATER</b>	
<b>Heat Pump Unit Not Powered</b>	Check to ensure the electric isolating switch at the switchboard (usually marked "Hot water" or "Water heater") is turned on. (note that the compressor may not start up for 2 minutes after power is turned on).
<b>Excessive hot water consumption</b>	Often, end users are surprised at the amount of hot water used, especially when showering. If the amount of hot water used during the day exceeds the storage capacity of the cylinder, it is likely there will be insufficient hot water.
<b>Pressure &amp; Temperature Relief (PTR) Valve continually discharging water</b>	<p>It is normal and desirable that this valve allows a small quantity of water to be discharged during the heating cycle. If it discharges more than a bucket of water during a 24 hour period or discharges continuously there may be another problem.</p> <p>If the valve dribbles continuously, try easing the valve gear for a few seconds as described in the section 'Excessive Discharge from Safety Devices' on page 8. This may dislodge any foreign matter and alleviate the problem.</p> <p>If the valve discharges at high flows, especially at night, it may be as a result of the water pressure exceeding the design pressure of the water heater. Ask your installer to fit a Pressure Limiting Valve (PLV).</p>
<b>Expansion Control Valve (ECV) continually discharging water</b>	<p>It is normal and desirable that this valve allows a small quantity of water to be discharged during the heating cycle. If it discharges more than a bucket of water during a 24 hour period or discharges continuously there may be another problem.</p> <p>If the valve leaks continuously, try easing the valve gear for a few seconds as described in the section 'Excessive Discharge from Safety Devices' on page 8. This may dislodge any foreign matter and alleviate the problem. If this does not alleviate the problem contact Rinnai.</p>
<b>Ambient conditions too hot</b>	To protect the components of the heat pump unit it may not operate when the ambient temperature is higher than 43°C. The heating element will operate if water heating is required, but may take longer to heat the water.
<b>Ambient conditions too cold</b>	To protect the components of the heat pump unit it may not operate when the ambient temperature is less than -7°C. The heating element will operate if water heating is required.
<b>NO WATER FROM THE TAP</b>	
<b>Restriction in the hot tap or failure of the cold water supply to the water heater</b>	Check for water flow at the other taps and that the cold water isolation valve is fully open.

HIGH ELECTRICITY BILLS	
<b>Excessive hot water consumption</b>	See entry under the heading 'Insufficient or no hot water'
<b>High Electricity Tariffs</b>	The electricity tariff will determine the running costs of the system. It is important the end user is aware of the applicable tariffs. Contact your electricity supplier to confirm what these tariffs are.
<b>Higher Element Usage</b>	In extremely cold conditions the element may be operating more than normal.
WATER FLOW FLUCTUATIONS	
<b>One or more hot taps opened at the same time</b>	More than one or two hot taps in use at the same time may cause a decrease in the hot water flow from the taps.  Is there more than one or two hot taps open, or are appliances such as a dishwasher or washing machine, in use at the same time?  Ensure only one or two hot taps are on at one time.
WATER HAMMER	
<b>Hot and cold water plumbing in the premises</b>	Have a plumber check clipping of hot and cold water pipe work and install a pressure limiting valve and water hammer arrestor as required.
HEAT PUMP ICES UP	
<b>Defrosting function</b>	The heat pump has a built in hot bypass defrosting function which may operate and remove any ice.
HEAT PUMP ERROR INDICATOR	
When an Error is detected with the Heat Pump, the "Fault" icon on the display screen will illuminate, and the setting temperature window displays the current fault code:	

**FAULT CODES**

Fault Code	Description	Fault Code	Description
E1	Water temperature sensor	E0	Parameter error fault
E2	High voltage fault	EA	High temperature protection of compressor exhaust air
E3	Fin temperature sensor	Ed	Antifreeze protection
E4	Ambient temperature sensor	Et	The ambient temperature is not in the operating range of the heat pump
E5	Return air temperature sensor	EE	High compressor current
E6	Exhaust temperature sensor	Eb	Low compressor current
E7	Low pressure protection	EF	Communication fail
E8	Hot water temperature sensor		

# SPECIFICATIONS

## SYSTEM SPECIFICATIONS

Model		EHPT180VM
Net Weight / Filled Weight (kg)		100 / 281
Sound Level		48 dB(A)
Ambient Temperature Limits (for heat pump operation - element will operate beyond these limits)		-7°C to 43°C
Ingress Protection		IPX4
Storage Cylinder - Hot Outlet and Cold inlet Connections		ISO 7.1 ¾" RP
Storage Cylinder - PTR Valve Connection		ISO 7.1 ¾" RP
Pressure & Temperature Relief (PTR) Valve (Supplied) Setting / Rating		850 kPa / 30kW
ECV Fitted	Fit PLV if mains pressure exceeds	680 kPa
	Recommended PLV pressure rating	500 kPa
ECV Not Fitted	Fit PLV if mains pressure exceeds	800 kPa
	Recommended PLV pressure rating	500 kPa
Rated Input Electric Element (Factory Wired)		1.5 kW
Maximum Input Refrigeration Module (Factory Wired)		0.9 KW
Total Maximum Input		2.4 KW
Maximum Energy Output (Use to size PTR)		5.5 kW
Power Supply		220-240 V AC, 50 Hz.
Maximum Current		11 Amps (15 Amp plug fitted)
Refrigerant Type / Mass		R134a / 1 kg
Refrigerant Circuit Maximum Pressure		2700 kPa
Coefficient Of Performance (COP)	32.6°C Ambient 21.1°C cold water inlet	7.5
Heat Output	32.6°C Ambient 21.1°C cold water inlet	3.1 kW

**DIMENSIONS**

Model	EHPT180VM
Cylinder height	1730
Hot Outlet / PTR (A)	1035
Cold water inlet (B)	145
Cylinder diameter	570

All Dimensions in mm

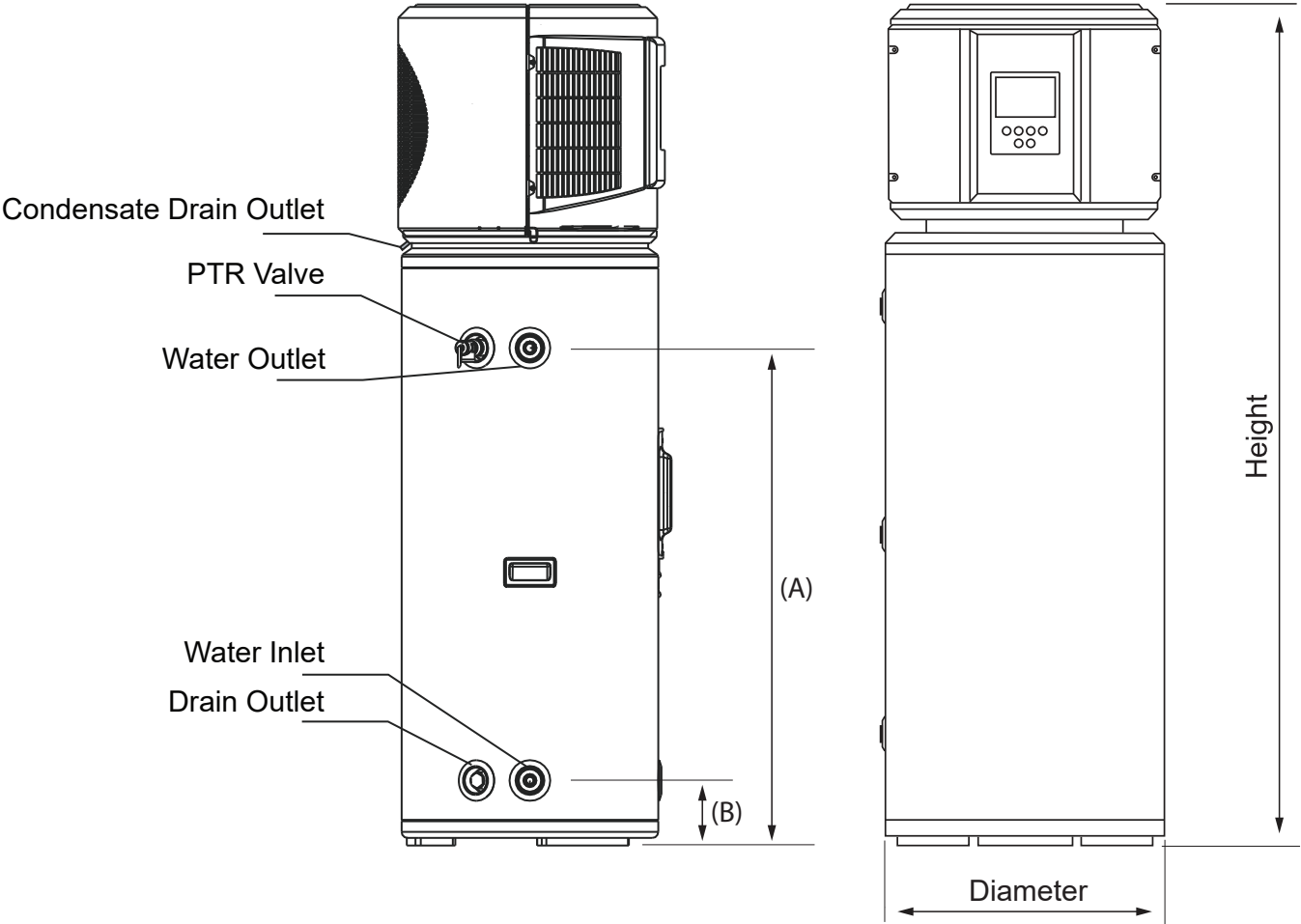

## SPECIFICATIONS

### CLEARANCES

Allow 600mm on the plumbing connection side and 200 mm clearance on the fan suction side to allow for sufficient air flow through the fan.

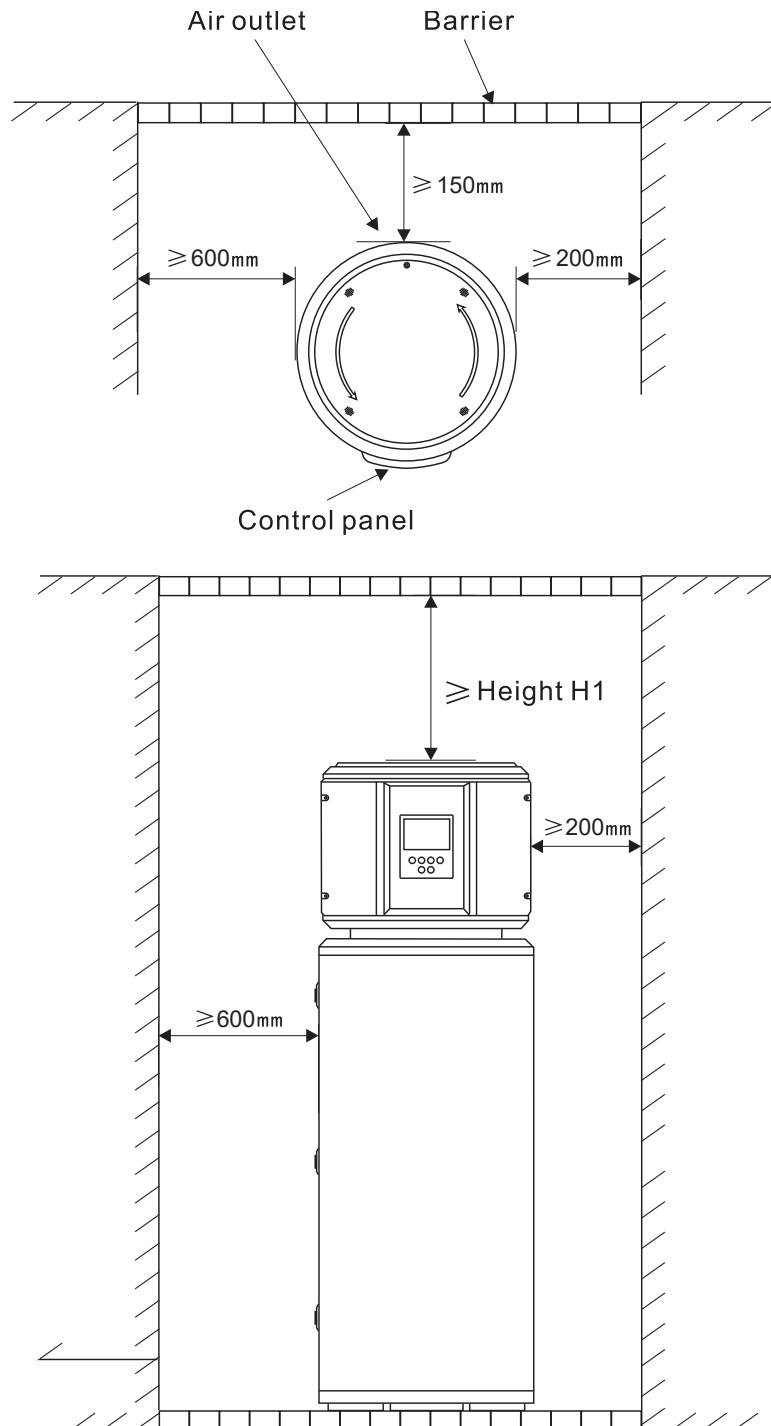

Model	EHPT180VM
Min Clearance Height H1 (mm)	550

# INSTALLATION

## REGULATIONS AND OCCUPATION HEALTH AND SAFETY (OH&S)



Installation and commissioning **MUST** be performed by authorised persons.

The heat pump **MUST** be installed in accordance with these instructions and all regulatory requirements which exist in your area including those in relation to manual lifting.

Applicable publications and regulations may include:

- AS/NZS 3500 National Plumbing and Drainage
- AS/NZS 3000 Wiring Rules
- Building Codes of Australia (BCA)
- Local Occupational Health and Safety (OH&S) regulations

This appliance is not suitable for use as a domestic spa pool or swimming pool heater.

Electric Heat pumps are heavy and bulky items. Australian States and Territories have Principal Occupational Health and Safety (OH&S) Acts with requirements relating to handling of large, bulky or awkward items. Persons installing heat pump systems **MUST** be aware of their responsibilities and be adequately trained and qualified, in accordance with local OH&S requirements.

## LOCATION

The electric heat pump can be installed externally or internally.

The electric heat pump should be placed as close as practicable to the most frequently used hot water outlet point or points to minimize the delay time for hot water delivery. This will usually be the kitchen tap. For installations where the distance between the heat pump and the outlets is considerable, a flow and return system can be used which minimize the waiting time for hot water delivery.

It is recommended that all components are installed at ground or floor level with consideration for easy service, repair or replacement access.. The heat pump **MUST** be installed in a vertically upright position. All components **MUST** be accessible without the use of a ladder or scaffold. The unit **MUST NOT** be installed in roof spaces.

The air inlet and outlet of the heat pump module **MUST** be away from areas with strong wind and **MUST** be provided with sufficient clearances as per those shown in the section 'Clearances' on page 14.

The heat pump **MUST** be connected to an independent AC 240 V, 50 Hz power supply.

Ensure the pressure and temperature pressure relief (PTR) valve and any access covers have sufficient clearances and are accessible for service and removal. The information on the rating plates **MUST** also be readable.

The heat pump **MUST** be installed free-standing on a level and stable base no more than 2° off perpendicular to level ground. The cylinder should be mounted on a concrete base at least 50mm thick or on, evenly spread hardwood slats with a thickness of at least 25mm. Where property damage can occur as a result of water leakage, the storage cylinder **MUST** be installed with a safe tray (overflow tray) at least 50mm larger than the diameter of the water heater and drain in accordance with AS 3500.4. Ensure the storage cylinder **DOES NOT** stand on wet surfaces.

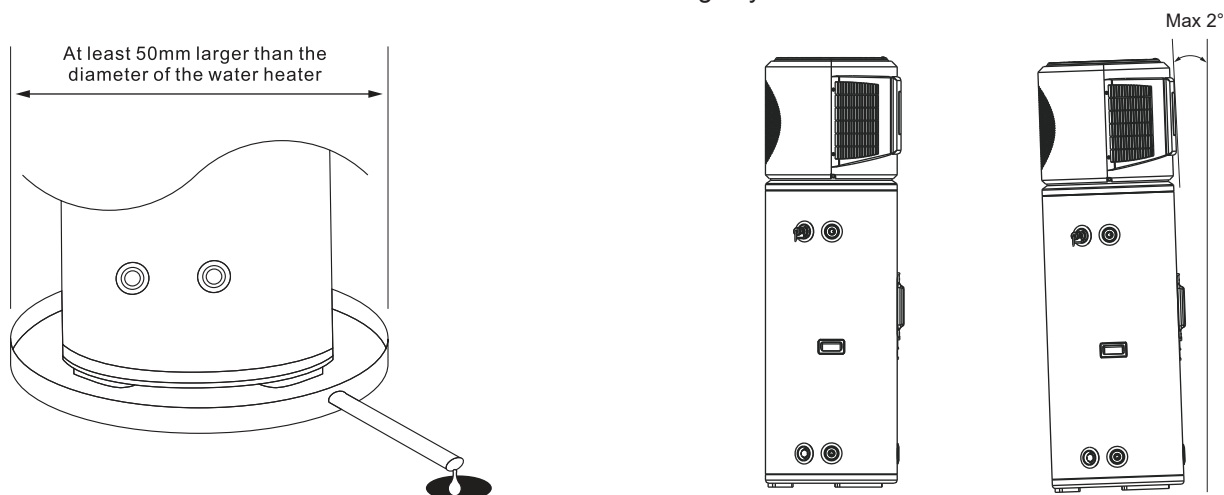

### Internal Installation

For internal installations the area **MUST** meet the following requirements:

- Minimum room volume of 10m<sup>3</sup> per unit.
- Good Ventilation (i.e minimum 200 L/s per unit)
- Away from any ignition sources or corrosive environments.

If the heat pump is installed internally careful consideration should be taken in regards to positioning and limiting the effect of unit noise and reverberation during operation.



Ensure the location complies with the requirements of AS/NZS 60335.2.40 & AS / NZS 5149.

### Condensation

As this heat pump is highly efficient the surrounding air temperature could be cooled by up to 4°C and condensate formed, the condensate will need to be plumbed to a suitable drain.

### Drainage

Where property damage can occur as a result of water leakage, the water heater **MUST** be installed with a safe tray (overflow tray) and drain. Construction, installation and draining of the safe tray **MUST** comply with local regulatory requirements and AS/NZS 3500.4 also requires the use of a safe tray for particular situations.

### WATER SUPPLY

This appliance is intended to be permanently connected to the water mains and not to be connected by a hose set. The maximum water pressure is listed on page 12. An approved pressure limiting valve may be required if the maximum rated water supply pressure is exceeded.

Water chemistry and impurity limits are detailed in the separate warranty document. Most metropolitan water supplies fall within these requirements. If you are unsure about water quality and suitability, contact your water authority.

A water filter **MUST** be fitted on the inlet to the tank to prevent sludge or foreign matter entering the system.

In a scaling water supply, calcium carbonate and possibly other compounds are deposited out of the water onto any hot metallic surface and form a scale. Scaling water may cause scale deposits to form onto the metallic surfaces of the PTR valve and may prevent it from operating properly. To prevent this, an Expansion Control Valve (ECV) **MUST** be fitted on the cold water line after the non-return valve in areas of scaling water. ECVs **MUST** be fitted in South Australia and Western Australia to comply with local regulations.

### STORAGE TEMPERATURE

To meet regulatory requirements the thermostat control on the heat pump water heater is factory pre-set to 60°C. It is recommended that this temperature is not altered.

### HOT WATER DELIVERY TEMPERATURE

This appliance may deliver water at high temperature. Refer to the Plumbing Code of Australia (PCA), local requirements and installation instructions to determine if additional delivery temperature control is required.

The PCA, local regulations and the requirements of AS/NZS 3500.4 **MUST** be considered regarding the temperature limitations of hot water supplied to areas used primarily for personal hygiene.

The temperature of water to certain areas is limited to different temperatures according to purpose, for e.g. early childhood centres, primary and secondary schools and nursing homes or similar facilities for young, aged, sick or people with disabilities and for all other buildings. To comply with these requirements, a temperature limiting device, such as a thermostatic mixing or tempering valve, will be required on hot water systems.



## VALVES AND FITTINGS



A 30 kW capacity, combined Pressure and Temperature Relief (PTR) valve is supplied with the Heat Pump hot water system. This valve is fitted at the top of the storage cylinder. The PTR valve is a safety device and it is mandatory that it is fitted by the installer in all installations.

The following valves & fittings are to be supplied by the installer:

- A cold water Expansion Control Valve (ECV). An ECV **MUST** be fitted in Western Australia and South Australia to the cold water supply to the storage cylinder to comply with local regulations. An ECV is recommended in all other geographical areas where the water supply has a tendency to cause scaling. This will reduce hot water discharge from the pressure and temperature relief (PTR) valve which minimises wear on this valve.
- A stop cock, non return valve and line strainer. Combination valves incorporating two or more of these functions (such as 'Trio' valves) are suitable. These are fitted to the cold water supply to the storage cylinder by the installer.
- Cold water supply and hot water discharge pipework to and from the storage cylinder. This pipework **MUST** be insulated as specified in AS/NZS3500.4
- An approved pressure limiting valve (supplied with some systems) is required if the maximum rated water supply pressure on page 12 is exceeded.
- Tempering valve(s) or thermostatic mixing valve

## TRANSPORT AND HANDLING



When moving the unit, it **MUST** be close to vertical at all times.

When using a trolley to move the unit, ensure it is not tilted more than 45° from the vertical.

Non compliance will void warranty and severely affect product performance and operation

The Rinnai Electric Heat Pump **MUST** be transported at an angle no greater than 45° from vertical.

As the compressor unit is located at the top of the electric heat pump, should the heat pump be tilted at a greater angle than 45° from vertical, the lubrication oil within the compressor can run down into the mufflers.

This will leave the compressor motor without sufficient lubrication and lead to premature failure of the compressor unit.

As a general good practice it is better to keep the compressor upright as much as possible to avoid any risks. Returning the Rinnai Electric Heat Pump to a vertical position will allow the oil to properly flow back into the compressor motor.

Tilting the heat pump beyond 45° from vertical will also place undue strain on compressor motor mounts and associated piping.

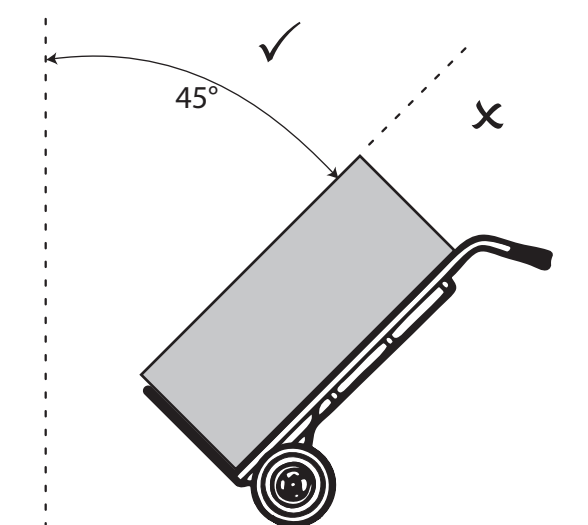

Never tilt unit more than 45° from vertical

## INSTALLATION

### POSITIONING THE HEAT PUMP

Arrive at site and conduct a safety audit (Safety audits can also be known as Work Method Statements (WMS) or Job Site Analysis (JSA)).

Park your vehicle as close as allowable to your installation. Unload all materials in a safe manner.

Position all materials in a convenient position near the work area.

Refer to "Location" on page 15 positioning consideration and requirements for all installations. Where the requirements for internal installation can't be met, the heat pump **MUST** be installed outdoors.

The location **MUST** also consider noise impact on living areas. Avoid positioning near bedrooms or neighbours' bedrooms. Although the running noise level is very low it can be expected that the heat pump will run during the night.

Adequate access **MUST** be available to the relief valve and anode.

Safely position the new unit on a level surface in accordance with all plumbing and building regulations.

A properly drained overflow tray **MUST** be used where property damage could occur from water spillage. (See AS/NZS3500.4.2 for further details.)



**DO NOT** drain on to grass or garden beds.

**DO NOT** commence a job where the risks cannot be controlled.

Ensure the requirements specified in the section 'Clearances' on page 14. are complied with. The area **MUST** also be clear of debris such as leaves and tree branches.

### CONNECT THE PTR VALVE

Connect the PTR valve to the uppermost fitting of the storage cylinder. See the diagram on page the section 'Dimensions' on page 13.

The PTR pressure rating **MUST** be suited for the cylinder and adequate for the thermal loading applied to the storage cylinder, as specified in the table on 12. The supplied PTR valve input rating is 30.0 kW. The PTR valve rating **MUST EXCEED** the total input from the heat pump. For example, the maximum output is 5.5 kW (see the table on page 12). This is less than 30.0 kW, hence the supplied PTR valve is of sufficient capacity.

Use Teflon thread tape on the valve, never use hemp or other sealing materials. Ensure the tape does not protrude past the end of the thread, which could result in it hanging over the end of the thread and blocking the water passage through the valve.

Connect the supplied PTR valve into the top socket marked "Relief Valve". Leave the valve outlet pointing down. Tighten the valve using the spanner flats - never use the valve body. Discharge according to plumbing regulations. PTR Valves for the unit are rated at 850kpa.

The drain line from this valve **MUST** run in a continuously downward direction with the discharge end left permanently open to atmosphere.

### PLUMBING CONNECTIONS

Refer to the diagram on page 20 for detailed information on position of plumbing.

An approved isolating valve, non return valve, line strainer, and union **MUST** be fitted between the supply main and the RP 3/4 socket in the water heater. All fittings **MUST** be approved by the relevant installation Authority.

An ECV **MUST** be fitted in Western Australia and South Australia to the cold water supply to the storage cylinder to comply with local regulations.

An ECV is recommended in all other geographical areas where the water supply has a tendency to cause scaling.

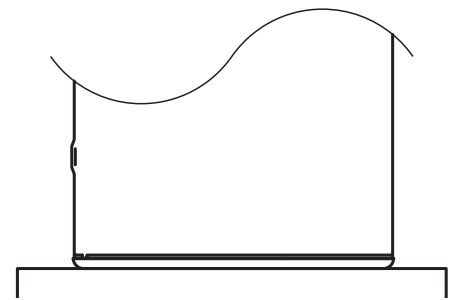

Install a plinth under the heat pump where it is subjected to wet conditions

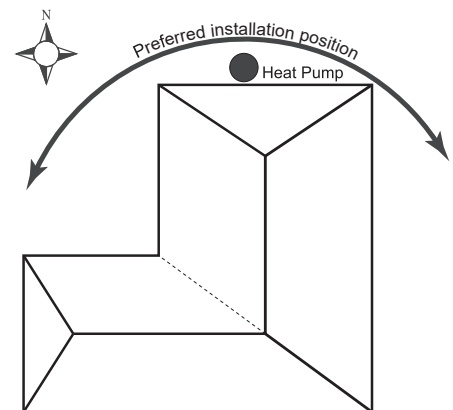

Optimum installation location is on the warmest side of house.

This will reduce hot water discharge from the pressure and temperature relief (PTR) valve which minimises wear on this valve.

This water heater is designed for direct connection to water supply pressures of no greater than those specified on page 12. Where the mains pressure can exceed or fluctuate beyond this, a pressure limiting (PLV) device (complying with AS1357) **MUST** be fitted.

**CONNECT COLD / HOT WATER SUPPLY**

Connect cold water supply, Pressure Limiting Valve (PLV) and or Expansion Control Valve (ECV).

Connect cold water supply to the storage tank (refer to Diagram BELOW).

A stop cock, non return valve and line strainer **MUST** be fitted.

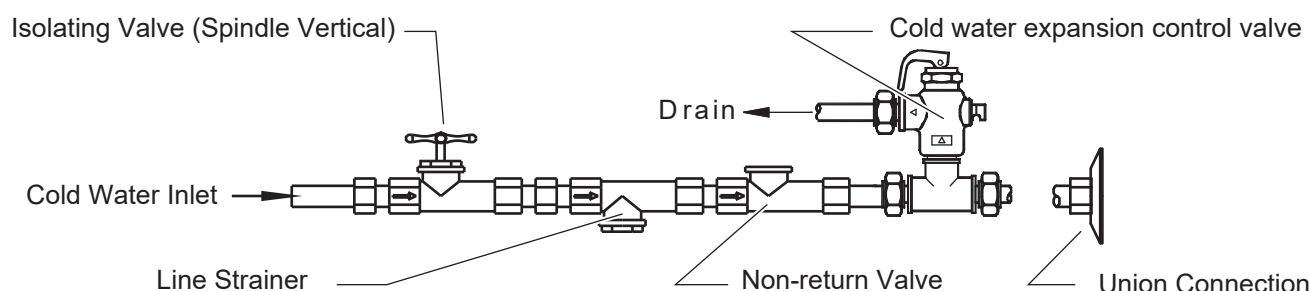

Connect the pipe work supplying hot water to the premises to the hot water outlet on the tank.

A temperature limiting device may be required as detailed in the section the section 'Hot Water Delivery Temperature' on page 16

It is recommended that all hot water lines are insulated with high temperature, UV resistant 13mm closed cell insulation.

**CONNECT CONDENSATE DRAIN LINE**

A condensate drain line is required to be fitted to carry discharge clear of the water heater.

The condensate drain line should not be connected to the PTR drain line but can exit to the same point.

The diagram below shows the location of the condensate drain on the heat pump. Use the supplied PVC pipe (inner diameter 9mm, UV resistant) to connect to the condensate outlet.

Independent 15mm copper pipes **MUST** be fitted to the drain outlets of the PTR and ECV.

Each pipe **MUST** be open to atmosphere and run with a continual downward grade in a frost free environment to a visible discharge point.

Drain lines **MUST** not exceed 9 meters in length.

Valves or other restrictions **MUST NOT** be placed in the relief valve drain outlet line.

**TYPICAL PLUMBING LAYOUT**

EHPT180VM

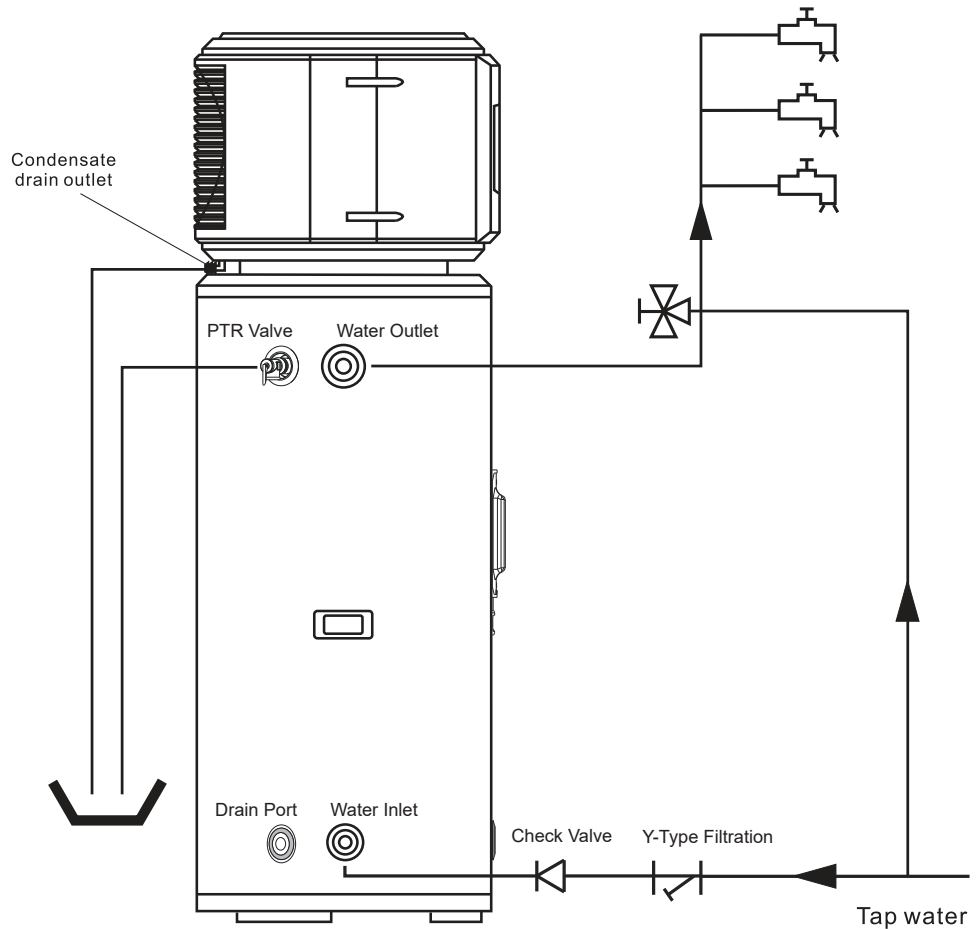

**ELECTRICAL CONNECTIONS**



WARNING

The power supply to the heat pump module **MUST NOT** be activated until the system is filled with water.

The premises wiring to the heater **MUST** be capable of withstanding the appliance load. Refer to specification table for load details.

All electrical connections and wiring **MUST** be installed, maintained and removed by authorised persons in accordance with AS/NZS 3000, and all other relevant local regulations and municipal building codes including OH&S requirements.



IMPORTANT

The Heat Pump is fitted with a power cord & 15 amp plug, It **MUST** connect to an independent, fused, AC 240V 50 Hz power supply with an isolating switch installed at the switch board, which shall effectively isolate all active supply conductors from the circuit and means for disconnection **MUST** be incorporated in the fixed wiring in accordance with the wiring rules.

A Residual Current Circuit Breaker is recommended for the power supply to this appliance (this may be a mandatory requirements in some states or jurisdictions).



This appliance **MUST NOT** be connected via a switchable or a solar (photovoltaic - PV) power supply without manufacturer consultation and authorisation.

The switching of the supplies will place the water heater into a re-start cycle which reduces the available heating time and may result in a lack of hot water.

It is recommended this appliance is connected to either a 24 hour continuous tariff or an extended off-peak power supply (minimum 16 hours per day), noting that the minimum required running time is governed by hot water demand and the climate zone.

If this appliance is replacing an electric water heater with a capacity of 250 litres (or greater), then a connection to a 24 hour continuous tariff supply is recommended.

Disconnect all power prior to installation and commissioning.

This appliance is designed for single phase 240 Volts, AC mains electrical operation.

**Cord Management**

Make sure that the power cord attaches to the power outlet at a point higher than it exits the appliance (1). Alternatively loop the cord (2) so that any water is not directed to the the power socket.

1. Mount socket outlet higher than cord outlet

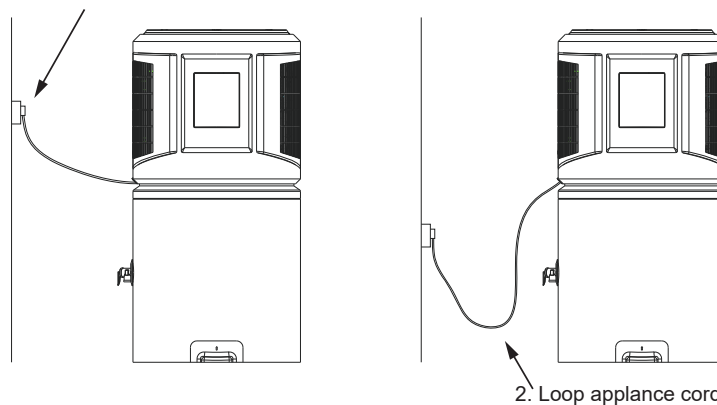

**WIRING SCHEMATIC**

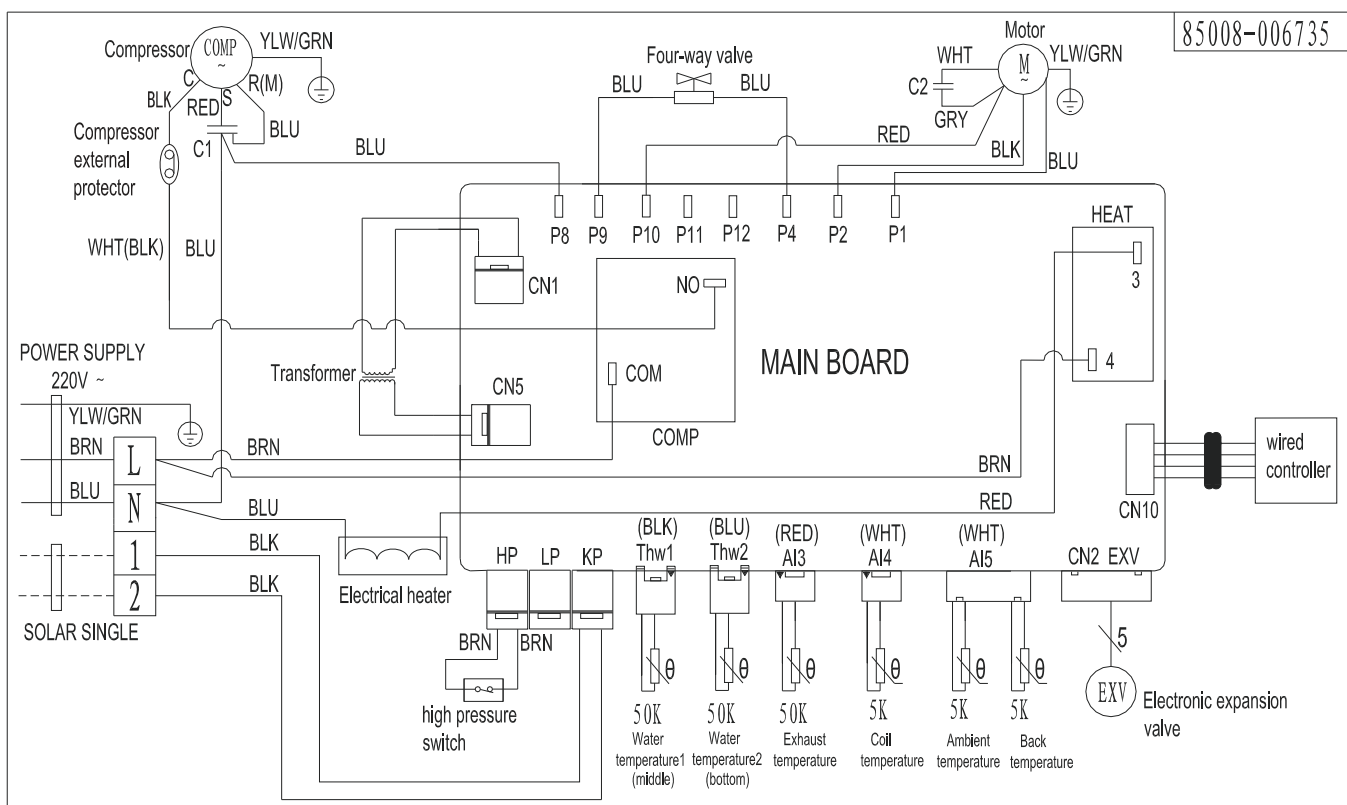

### ELECTRICAL TESTS

**DO NOT** turn on the power supply to the appliance until it has been filled with water and a satisfactory insulation (Megger) test has been performed.

#### Conducting Insulation (Megger) Tests

When conducting an insulation test using a Megger on this appliance, observe the then the following:



This appliance contains electronic components, when performing insulation tests (500 Volts) this **MUST ONLY** be conducted the across active terminal to earth and then across the neutral terminal to earth.

Tests between the active to neutral terminals **MUST NOT** be performed as this **WILL** damage the electronic components.

Insulation test results of between **100 kΩ** and **660 kΩ** are normal for this appliance.

In accordance with AS/NZS 3000 an insulation test with a result less than **1 MΩ** is permitted where the appliance is approved to a Standard applicable to that class of appliance.

This appliance is categorised and certified as a 'stationary Class 1 motor operated appliance' and therefore satisfies the requirements of AS/NZS 60335.2.40 for leakage current and electric strength. As such, this appliance complies with the insulation resistance requirements of AS/NZS 3000.

### FILLING THE SYSTEM

Open hot water tap at sink.

Open the stop cock in the cold water main supply line. Allow the system to fill and the air to bleed through the tap.

Turn off the hot tap at the sink when water flows freely without any air bubbles or air bursts.

Bleed any remaining air from the PTR valve.

If leaks are detected turn off power to the heat pump, repair any leaks and repeat the filling process to remove any air.

If no leaks are detected water heating can commence. The heat pump will start up after the 2 minute protection delay.

### COMMISSIONING AND FINISHING THE INSTALLATION



Please confirm the following before commissioning:

- Piping and electrical wiring are all correct
- Earthing wire is installed properly
- Pipe insulation is completed
- Tank is filled
- Supply Voltage complies with rated voltage
- Air intake and discharge are not obstructed

Turn on power to the heat pump unit and wait a few seconds for the system to start. Change operation mode or water temperature setting if required (it is recommended to retain default setting however).

After testing is completed, explain to the customer the functions and operation of heat pump water heater components. Explain the need to drain the heat pump if freezing conditions are likely or power is likely to be shut off for an extended time.

Also explain to the customer the importance of carrying out maintenance in accordance with this manual. Leave the manual with them upon completion of the installation.



**DO NOT** drill, screw or fix any ancillary items to the of the tank. This product is fitted with a high efficiency heat exchanger attached to the inner cylinder, anything penetrating the outer skin of the tank may damage the heat exchanger.

## CONTROLLER LAYOUT



### Controller Icons

Icon	Description	Icon	Description
	Eco Mode		Compressor State
	Hybrid Heating Mode		Electric Heating State
	Electric Heating Mode		Child Lock
	Temperature Setting		Tank Temperature
	Fault Warning		Wi-Fi State
	Timer		Clock Display

### Control Keys

Key Symbols						
Function	Power On/Off	Mode / Lock	Timer	Settings	Temperature Up	Temperature Down

When the unit is powered on, all the symbols will be displayed for approximately 2 seconds.

**OPERATING FUNCTIONS**

**On / OFF**



- In standby mode, press the 'on/off' key once to perform the startup function and display the mode before the last shutdown.
- In the start-up mode, press the 'on/off' key once to shut down the appliance.
- Press 'SET' and 'On/Off' together and hold for 3 seconds to enter the Wi-Fi setting functions.

**Mode / Lock**



Press the 'MODE' key to cycle between Modes in this sequence: ECO → HYBRID → E-HEATER

- **Eco mode:** The unit is set to economy mode, the hot water temperature is adjustable in the range of 30-60°C, the compressor is running at 30-60°C.
- **Hybrid heating mode:** The unit is set to hybrid heating mode. The hot water temperature is adjustable in the range of 30-70°C. The compressor and electric heating are running at 30-60°C, and the electric heating is running at 60-70°C.
- **Electric heating mode:** The hot water temperature is adjustable in the range of is 30-70°C, the electric heating will be operated within this range.

Every time the unit is powered on it will automatically enter the last operational mode it was in before shutdown.

**Locking function**

- Press and hold the 'MODE LOCK' key for 3 seconds to activate the child lock. Press and hold again for 3 seconds to release the lock.

**Timer**



**Timer setting**

- Press the "TIMER" key for 3 seconds and then release to enter the time setting. The hours and minutes in the time display area will flash at the same time. Press the "TIMER" key again, and the hours in the time display area flash. Press the "up" key or "down" key to adjust the hours; Press "SET", and the minutes in the time display area will flash. Press the "up" key or the "down" key to adjust the minutes; After the time setting, press the "SET" key to save and exit.

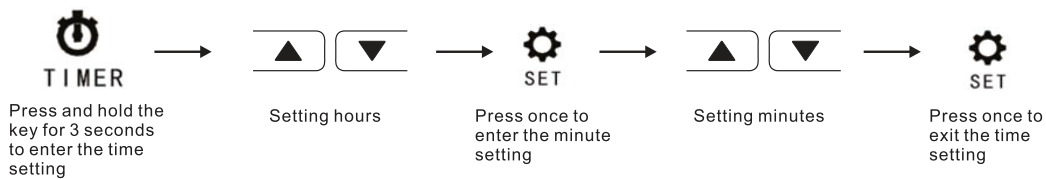

**Timed start-up**

- When there is no timing setting in the normal interface, press the "TIMER" key once to enter the timed startup setting interface and timer symbol in the time area will flash, and "ON" is displayed in the temperature area of the water tank. The default time display is 00:00, and the hour area flashes. Press the "SET" key to switch to the minute setting, and the minute area flashes. Then press the "SET" key to switch to the timed shutdown setting.

**Timed shutdown**

- The timer symbol in the time area flashes, and "OFF" is displayed in the temperature area of the water tank. The default time display is 00:00, and the hour area flashes. Press the "SET" key to switch to the minute setting, and the minute area flashes. Then press the "SET" key to save the timer setting.

**Cancel timing**

- When the timer is active, press the "TIMER" key once to cancel the timing.



## Settings



The key is used in timed startup and timed shutdown setting, see the previous timing setting operation for details;

# SET

- Press and hold the “SET” key for 3 seconds to enter the parameter inquiry page. This function is mainly intended for use by qualified installation and maintenance personnel. See the following table for parameter details:

Code Description	Number	Remarks
Tank temperature 1 (Thw 1)	01	Unit: °C
Tank temperature 2 (Thw 2)	02	Unit: °C
Ambient temperature (Ten)	03	Unit: °C
Fin temperature (Tfr)	04	Unit: °C
Compressor exhaust temperature (Tcomp)	05	Unit: °C
Return temperature	06	Unit: °C
Current of compressor	07	Unit: Amps
Current opening state of electronic expansion valve	08	States: Open/Closed
Set mode	09	00-Eco Heat, 01-Hybrid Heat, 02-Electric Heat
Heating set temperature (Ts)	10	Unit: °C
Display water temperature	11	Unit: °C
Controller version number	12	Example: A05
Controller version number	13	Example: A01
Jumper cap setting model number	14	Examples: 01 02 03
Last fault code	15	Example: E1
Second last fault code	16	Example: E1
Third last fault code	17	Example: E1
Fourth last fault code	18	Example: E1

## Temperature Up/Down



- “Temperature ▲”: The set temperature is increased by 1°C
- “Temperature ▼”: the set temperature is decreased by 1°C



- During operation, enter the sequence “[ ▲ ] - [ ▼ ] - [ ▲ ] - [ ▼ ] - [ ▲ ] - [ ▼ ]” within 5 seconds to initiate forced defrosting.

**WI-FI CONNECTION**

Please follow below steps to set up and operate Wi-Fi functions.

1. Prepare a Wi-Fi wireless router that can access the Internet, The Wi-Fi frequency band is required to be 2.4 Ghz and it should be placed within 10 meters of the water heater to ensure that a strong Wi-Fi signal is available.
2. Turn on Wi-Fi and Bluetooth on your device. After the connection is successful, you can turn off Bluetooth and operation will not be affected.
3. Scan the QR code below or search in the app market to download and install the ‘Smart Life’ App.
  - iOS users – please download from App Store
  - Android users – please download from Google Play



4. After completing the installation, open the App, register an account and log in according to the App prompt.
5. Power on the water heater, press ‘Setting’ and ‘On/Off’ together and hold for 5 seconds to enter the Wi-Fi setting functions. The Wi-Fi icon on the display will be flashing.

**NOTE** **Wi-Fi connecting is available for 3 minutes. You will need to repeat step 5 if the icon stops flashing during the connection**

6. Connect to the SmartLife App as follows:

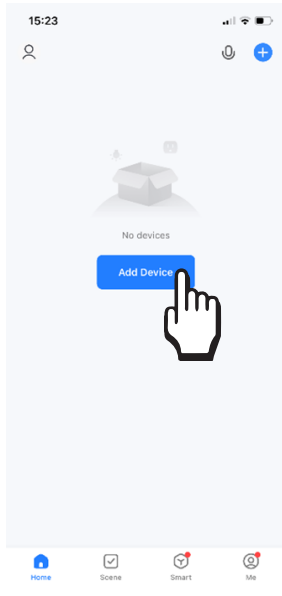

i) Search for Device

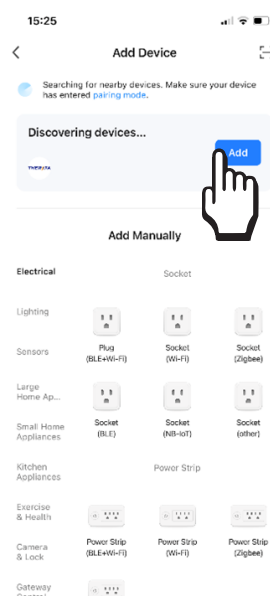

ii) Add Found Device

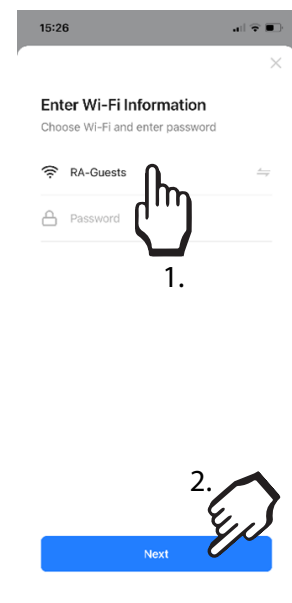

iii) Connect to Wi-Fi

Connect to SmartLife App (cont).

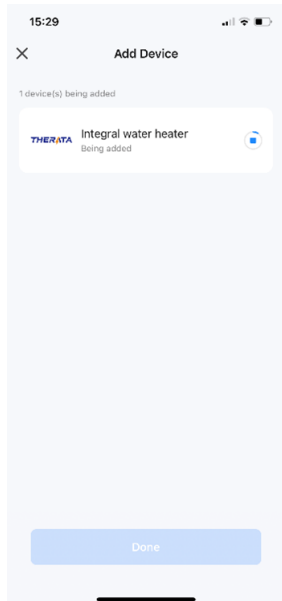

iv) Wait for Connection

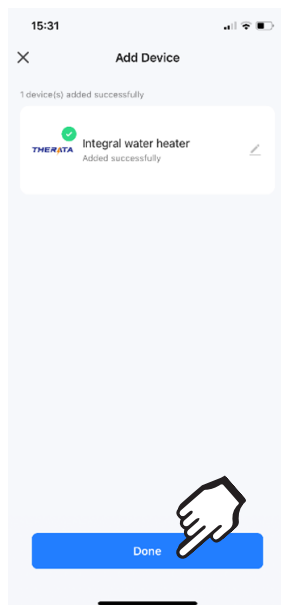

v) Complete

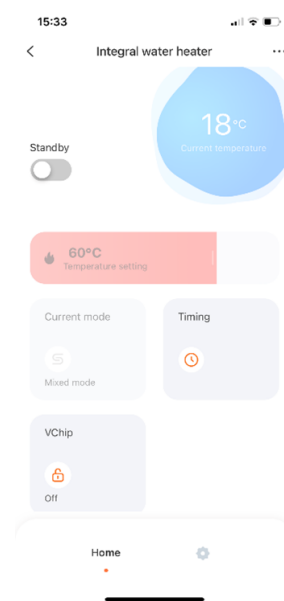

vi) Device Connected

7. Control the Heat Pump with the App

The main controls for the App are laid out as follows on the App.

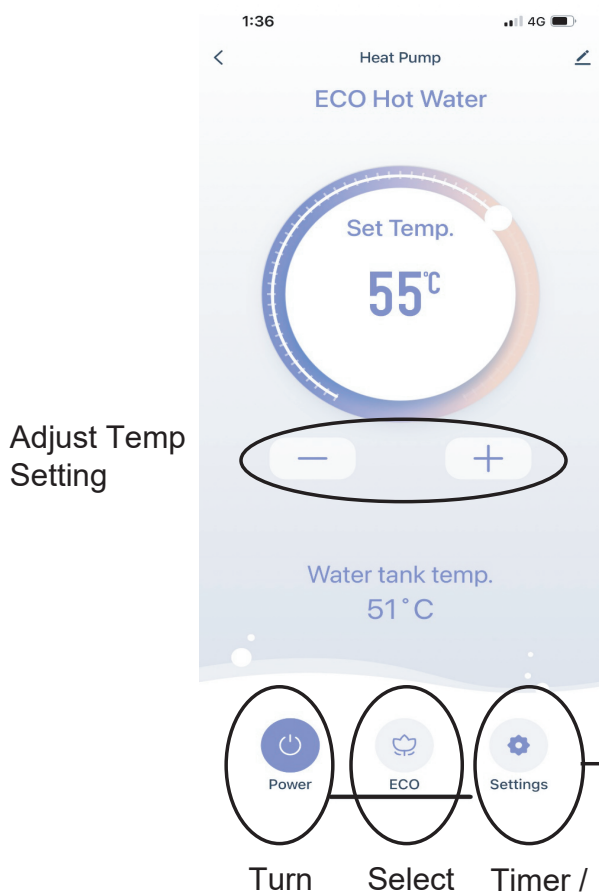

Adjust Temp Setting

Turn      Select      Timer /

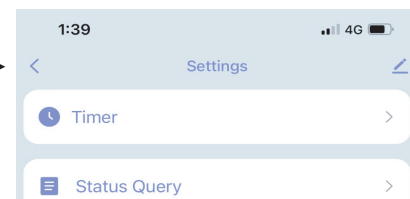

# Rinnai Australia Pty Ltd

ABN 74 005 138 769 | AU45204

100 Atlantic Drive, Keysborough, Victoria 3173

P.O. Box 460, Braeside, Victoria 3195

Tel: (03) 9271 6625

Fax: (03) 9271 6622

## **National Help Line**

Tel: 1300 555 545\* Fax: 1300 555 655

*Monday to Friday, 8.00 am to 5.00 pm EST.*

## **After Hours Hot Water Service Line**

Tel: 1800 000 340\*

*\*Cost of a local call may be higher from a mobile phone.  
(National calls from public phones in Australia are free.)*

For further information visit **[www.rinnai.com.au](http://www.rinnai.com.au)**  
or email **[enquiry@rinnai.com.au](mailto:enquiry@rinnai.com.au)**

Rinnai has a Service and Spare Parts network with personnel who are fully trained and equipped to give the best service on your Rinnai appliance. If your appliance requires service, please call our National Help Line. Rinnai recommends that this appliance be serviced every 3 years.

With our policy of continuous improvement, we reserve the right to change, or discontinue at any time, specifications or designs without notice.